

HUMAN AFTER ALL

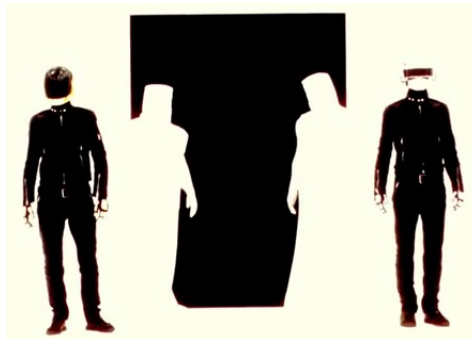

Image from Daft Punk movie "human after all"

By Javier de Rivera

For Prof. Johanna Drucker.

IS 291C – UCLA



This work overviews some of the issues addressed in the class around the topic of New Materialisms. In it, I critique and argue against the influence of Latour's philosophy on some authors of the New Materialisms and of some accounts of the (post)human condition. Particularly, the authors quoted and examined are Jane Bennet and Katherine Hayles.

This paper also includes alternative accounts of the same topics addressed by those authors. Accounts that are not original, but based on scientific and philosophic traditions. It is divided into four parts: Ontology, Epistemology, Agency and Politics

Note: in case you have no patience with Epistemology (pages VI-XIII), go directly to Agency and Politics, where is the juicy stuff.

ONTOLOGY

Humans and non-humans

Aristotle defined humans as rational and social animals, but his metaphysics were mostly based on intuition and speculative reasoning, without the methodological observation and critical epistemology that characterize modern sciences. The scientific account of humanity comes from the theory of evolution, from which we know that species evolve from one another by accidental mutations¹ and natural selection, when mutant adaptive individuals manage to reproduce more than others. Therefore, humans evolved from other species in a process that is non-linear, non-teleological, unfinished and unclear². A complex process that involved the development of technology, language and higher cognitive abilities.

Living beings are not categories that can be discretely classified according to their essence, all species are interlinked and related without clear-cut boundaries. They are not metaphysical essences, but empirical phenomena that exist and evolve in complex, systemic relations with their environment. The definition of the different species is made by the probabilistic identification of patterns of existence and particular characteristics. Evolution is also multi-directional, which means that species do not have to fit in a hierarchical system, although they have different degrees of complexity and perform different types of actions.

The use of “non-human” as a substantive, instead of an adjective, is ontologically unsustainable because it creates a single category which includes every other being or thing: plants, apes, planets, robots, infrastructures, machines, objects, meteorological phenomena, ideas, and so on. Plus, by creating a category from the negative of “human”, it assumes the existence of a human essence that can

-
- 1 The theory does not identify any common cause, force or agency that produce these mutations, that is why they are attributed to accidents or errors in the replication/reproduction of living beings. However, nothing stops religious or spiritual sensibilities to think – outside science – that there is a divine force pushing the beings to evolution.
 - 2 In the rhetoric of the 19th Century there were still teleological, humanist and religious interpretations associated to human evolution. However, the characteristics named in the text are the theoretical conclusions of the theory of evolution, at least as it is understood nowadays.

be present or absent in a being, instead of considering humans as an empirical phenomenon, as the rest of species. The term “non-human” is supposed to serve as an opposition to classic humanism that perceives humanity as an essence at the top of the “creation”. However, the awkward agglomeration of *everything* but humans in a single category, necroticizes the concept of a human essence: it is dialectically neglected but rhetorically glorified.

In the 21th Century, the ideal of a human essence could be easily dissolved by scientific research and keen reflection, but Latour's followers prefer to believe in the chimera of the non-human, only to emphasize the non-difference between humans and *everything* else. If we are going to neglect the specificity of human beings, why give them an essential (humanistic) category first? The flat ontology³ of the Actor Network Theory neglects the distinction between entities, hindering the understanding of their relations, because in a certain way knowledge comes from the recognition of differences. Furthermore, in this case the conclusion that humans and non-humans are equal in terms of agency is only valid under their particular epistemological frame. From any other point of view (with a minimum of empirical contact), there exists a wide range of living beings with different particularities and characteristics. Among them, human beings are able to perform actions with a kind of complexity that has not yet been seen in other species. In other words, we do not need any theoretical framework to identify that there are differences between species, and between living and non-living things, but we do need one to neglect this obvious observation.

Perceiving differences as the possibility of knowledge

Reductionism has been a successful intellectual strategy in the previous steps of the scientific development. Reducing the explanation of facts to the most simple possible cause or process helped to fight the holistic and diffuse claim of God's inscrutable reasons to make the world at it is. Instead of a reason (a Why?), positivists began trying to describe phenomena (a How?) in simple ways⁴. However, at the end of the 20th Century, as science – physical and social – developed, it became more and more

3 The term comes from DeLanda (2004), although it is applied here as a characteristic of ANT ontology and not in its more general sense of non-hierarchical ontology. What we are proposing is more a probabilistic and phenomenological ontology that take account of the empirical differences without reifying them.

4 A principle that was, probably, set for the first time by William of Ockam, and has been recreated in different forms in scientific epistemologies.

clear that there was a need for upgrading our knowledge systems in order to be able to take account of the complexity that lied behind phenomena.

That was the intention of the Paradigm of Complexity impulsed, among others, by Edgar Morin (2007), who proposed principles towards the integration of the sciences or the concept of *Unitas Multiplex*, which explain the paradigmatic coexistence of unity and multiplicity, of Being and beings. This idea has been identified as a major issue in philosophy and is also addressed by the General Systems Theory: if all the systems are necessarily open systems, then all the systems are connected together by energetic exchanges – that work at different levels – and therefore they form a big single system. This paradigmatic situation of being “open” but having boundaries is difficult to understand by plain, unidimensional logic, that is why it is necessary to develop abilities for complex thinking.

Humberto Maturana and Francisco Varela's (1980) theoretical development of autopoiesis was an important antecedent for this trend of complex thinking. The concept of autopoiesis attempts to explain the characteristics of the living systems from an organizational analysis, that is, without using the mysterious concept of “the energy of life” as the key explanation. This way, life could be explained as an emergence of systems that are able to auto-produce themselves due to the property of being “informationally closed”. This closure might not be as complete as the authors originally thought, but they made a great improvement by describing complex living systems as an emergent phenomenon. Ontologically, the main idea is that there are beings that have an internal dynamic structure that defines them as autopoietic unities, *different* from other things in their immediate environment.

From the point of view of agency, the main characteristic of this autopoietic systems is that they produce themselves by auto-organization and cell reproduction. Therefore, their basic agentic property is actively enabling the cause of their own existence. In other words, autopoietic systems *want* to live or have an inherent tendency towards trying to live more.

From a political perspective, the properties of autopoiesis support the idea that any living being is an end-in-itself, which inspires a certain attitude of respect for living beings that prevents us from “using” them as tools, just for our own purposes. Centuries before, Inmanuel Kant also developed this idea of

being an end-in-itself as a proper characteristic of human beings, putting it in relation with his formal Ethic and other philosophical ideas that inspired the principles of modern democracies and concept of universal human rights (Internet Encyclopedia of Philosophy, s/f). Another possible application to politics is to consider social systems according to autopoietic characteristics, although Maturana and Varela were reluctant to a direct translation of their theory into social sciences.

How can we know?

If we do not know just how it is that human agency operates, how can we be so sure that the process through which nonhumans make their mark are qualitatively different?

Jane Bennet – *Vibrant Matter* (2010, p. 34).

The structure of this question is auto-referential and expresses no real meaning, it is equivalent to saying: *If we do not know something, how can we be “so sure” that we can know it?* It simply says that we cannot really know anything, and therefore, all statements are equally valid. In the original text, after this quote, Bennet introduces an esoteric term from the Chinese tradition, apparently to overcome the limitations she finds in rational thinking.

If we do not know something, we can try to learn about it, acting as if knowledge was possible and as if there were an epistemological tradition of science and philosophy that could help us to improve our understanding of things, although we will not ever achieve perfect understanding.

According the the autopoietic theory, living systems have the agency of producing themselves, something that cannot be found in inert systems. Humans, as autopoietic systems, have that agency and also have representational and symbolic forms of knowledge and the ability of producing technology, so it seems their agency is highly different from the agency of... a non-human shoe.

EPISTEMOLOGY

Science showed us that maybe we cannot know what is true, but we can surely identify what is false. The basic criteria of scientific epistemology is falsability, that represents the process of knowing as a continual approach towards being “less wrong” than before. Modern philosophy, on the other hand, has showed us that language imposes on us certain limits on what can be thought and, at the same time, that there are infinite, different possible ways of representing the world (there are also infinite possible languages). Both sources of knowledge can be successfully articulated towards a better understanding by following some basic rules: internal coherence and neutralization of the bias⁵.

Knowing could be defined as representing the world inside the unity of an autopoietic system, a process that has also a performative effect both in the autopoietic system that perceives and “knows” and in its environment. Knowing is an action in itself, a performative action, because it constitutes the presence and existence of the perceiving being as an entity in relation to its environment⁶.

In humans, this knowledge's representation is symbolic, linguistic and highly complex, although not radically different from some animal's representation of the world: think in the mental maps of the elephants or the cognitive abilities of chimpanzees. Simpler beings, microorganisms, might not have any form of “representing the world inside themselves”, but they also are able to process dynamic information processing and biological adaptation.

The theory of relativity and other advanced insights from physics emphasize the importance of “the observer”. It seems the physic phenomena can be described only from the point of view of an hypothetical observer, they are *relative* to the observer. Heinz Von Foester introduced this insight to create Second Order Cybernetic, stating the importance of self-observation to maintain the auto-production of the system. This theoretic innovation improved the complexity of Cybernetics producing

5 It is not the intention of the text to settle the discussion of the “rules of knowledge”, but it seems a good idea to introduce some criteria: internal and external. With “neutralization of the bias” I mean the promise that arguments are not being shaped and distorted just to reach an interested conclusion, that rhetoric is used for clarifying purposes and not to hide inconsistencies.

6 There is no necessary dichotomy between representation and performance, representations can be performative, unless you are a *performative artist* trying to distinguish yourself from classic arts model based only on “representation”. That is, unless you want to use words as a mean of social distinction, and not as a way to apprehend the world.

the notion of self-observing systems and giving a better account of cognitive processes. Maturana and Varela take this further to develop their concept of autopoiesis⁷.

Observing “the observer”

However attractive the concept of “the observer” can be, philosophers have worried about that same issue for centuries: the whole history of epistemology and ontology is invested in the conceptual understanding of this hypothetical knowing subject that “observes”: Who is s/he? How does s/he observe and know? How does s/he exist? What is observation? To observe, there needs to be a subject that observes, a unity that performs the observation⁸. For self-observation there also has to be a distance between observer and observed. The mediation of language and technology are forms of improving and amplifying the capacity of self-observation, they are means that help us separate from ourselves.

In a higher sense, we can also talk about an “universal observer” that observes through us. Recalling the General Systems Theory, the absolute system that encompasses all the open systems could be using them as a mean of self-observation. However, these open systems are entities or unities at the same time as they are parts of the big system.

7 The Third Wave of Cybernetics, according to Katherine Hayles' (1999) interpretation of the story. Although Maturana and Varela always said they were doing something different, they acknowledged building on Cybernetics but also attempted to break the theoretical boundaries of the field.

8 Nietzsche's attack on “the subject” would be equally valid for “the observer.” His take – and others', like Freud – is directed against the classic assumption that humans are autonomous subjects, complete in themselves, masters of their lives, etc. The realization that we are not pure essences does not mean that we do not have some internal unity. Open systems are not really independent, but they are differentiated entities. Ideas like “it is not me observing, but something in me observes” or “thoughts are thought in my mind” are insightful and rich, but the existence of mysterious processes inside cognitive systems does not invalidate the existence of those systems, but on the contrary, proves it.

“I am the walrus!

“I’m he as you are he as you are me, and we are all together”

*There are no object, no subject... But there are events. I never act;
I am always slightly surprised by what I do.*

Bruno Latour – *Pandora's Hope* (1999, p 297)⁹



Who is I? Is not “I” a subject?

“I never act, events happen” could be a valid statement, indicating that I am just an event and not a subject. But then, how can an “event” be “slightly surprised”? Is not perceiving an act? And do you not have to be “someone” to be surprised? Latour continues saying also the “something inside me is surprised”. Does it not occur to him that this “something inside” could be *himself*?

Observation refers more broadly to perception, knowledge, awareness, consciousness. All those terms carry their own nuance, but all of them rest on one same characteristic or property. It is about unities/subjects that perceive/are aware/are conscious of their environment, and eventually are also able to perceive/ be aware/ be conscious of themselves. Everything begins with perception, awareness or consciousness, it is the “magic” property that allows beings to perceive and by that (performative) action, it constructs us as subjects in relation to the environment. Perception makes the break that “creates” the world: the subject and the object, the observer and the event.

The term consciousness can imply different levels of awareness, and vice versa. It can go from the basic sentience of all beings to the most reflexive form of self-consciousness (*Stanford Encyclopedia of Philosophy*, 2004), and in any of those different levels and variants, it represents the act by which the entity is informed about the inside/outside relations, an act necessary to maintain the “informational closure” of the autopoietic system. The same way we thought of different ontological forms of existence we can think in different forms of perceiving, because the existence of a being is determined by sentience.

9 Quoted in Bennet (2010, p 97)

In humans, the term consciousness can be also identified with the “controlled thought” enabled by language and which is at the core of the human enterprise of trying to understand the world. This consciousness expressed through reflexive use of language is at the beginning of the possibility of knowing. In this sense, the Cartesian¹⁰ *cogito ergo sum* is the first step towards a better understanding: the knowing subject has to construct itself – make himself present to himself – in order to engage in the act of knowing.

Language provides a means for self-consciousness, it provides distance between the observer and the self. However, this distance can also produce false representations of the self, as Hayles explains when she introduces the later work of Varela which is influenced by Buddhism: “Opposed to the false unity and self-presence of grasping consciousness is true awareness, which is based in actualizing within the mind an embodied realization of the person's ongoing processes.” (Hayles, 1999, p. 156.) The details of this false/true self-perception are a complicated issue that escapes the scope of this paper, but it is something worth noting. Also, we should note the association of the term “consciousness” as a false self-perception, and opposed to “awareness” as a true one is not self-evident, and would need a better definition of how the author(s) are using it. Particularly, because a quick attribution of particular meanings to such abstract and difficult concepts can lead to confusions when using those terms in different contexts:

First, the posthuman view privileges informational pattern over material instantiation, so that embodiment in a biological substrate is seen as an accident of history rather than an inevitability of life. Second, the posthuman view considers consciousness, regarded as the seat of human identity in the Western tradition long before Descartes thought he was a mind thinking, as an epiphenomenon, as an evolutionary upstart trying to claim that it is the whole show when in actuality it is only a minor sideshow.

(Hayley, 2010, p. 2-3)

10 We can be over the Cartesian metaphysic description of the subject, but still appreciate the valuable insights that he introduced in philosophy. After all, that is how knowledge evolve and is accumulated: taking the good points from old thinkers and trying to correct their flaws. Pretending to build complete new ontologies and epistemologies from the scratch is not only arrogant but normally disastrous.

In this portrait of the posthuman view, Hayles opposes the idea of consciousness as “the seat of human identity” and as “an emergent epiphenomenon”, being one “the whole show” and the other “a minor sideshow”. Maturana and Varela managed to describe human consciousness as an emergent property of the brain, which apparently means it is not very important in defining the human identity. However, in the story of human evolution the brain and its emergent properties seem quite relevant, actually the cognitive properties of humans are their main distinctive feature. However, being an epiphenomenon does not mean that something is not important: “epi-” from ancient Greek means surface, but does not necessarily have the connotation of *superficial, unimportant*. Think for a moment in an earthquake, the *epicenter* does not look like a sideshow, it is the center of the external manifestation of the *focus*, the place inside the earth that causes the earthquake. Consciousness as an epiphenomenon is also the external manifestation of the phenomenon of life in an autopoietic system.

Before this chapter, she presents the posthuman condition in relation with the possibility of downloading *the information* of the brain to a computer to extend life. That is why she presents the opposition between “informational pattern” and “material instantiation” as a key element to understand the posthuman view. Her point is that the material instantiation matters and the informational patterns are not independent from it. But what she does not consider is that “information patterns” are not the expression of life, that in order to be alive you have to be conscious: an autopoietic unity able to perceive. Downloaded information would not produce consciousness, it only emerges when it is embodied in an autopoietic system¹¹.

The term consciousness is again profusely used in Chapter Two, when science-fiction narratives are introduced to simulate the interaction between consciousnesses and computers:

Like the landscapes they negotiate, the subjectivities who operate within cyberspace also become patterns rather than physical entities. Case, the computer cowboy who is the protagonist of *Neuromancer*, still has a physical presence, although he regards his body as so much "meat" that exists primarily to sustain his consciousness until the next time he can enter cyberspace.

11 Which, oddly, is also one of her points.

Others have completed the transition that Case's values imply. Dixie Flatline, a cowboy who encountered something in cyberspace that flattened his EEG, ceased to exist as a physical body and lives now as a personality construct within the computer, defined by the magnetic patterns that store his identity.

(Hayles, 1999, p. 36)

Case needs his physical body to sustain his consciousness not only until the next time he can enter cyberspace, but also while he is in it. It is his working brain that let him participate in that “consensual hallucination”. In the novel, Dixie Flatline is dead, what remains is a program that captured his personality, the information in his brain. Case *uses* it as an interactive tutorial program to attack a dangerous target in cyberspace. It can maintain long conversations, but Case has to give it sequential memory if he wants it to remember him each time the program starts. Even in the original science-fiction source, dynamic perception (consciousness, sentience, etc) is a condition for being considered alive: *It was disturbing to think of the Flatline as a construct, a hardwired ROM cassette replicating a dead man's skills, obsessions, kneejerk responses....* (Gibson, 1984. p. 45)

Information patterns alone are not enough to produce life, there is a need for an autopoietic system – and organic, living systems are the only known autopoietic systems – to “power” that information so consciousness can emerge. The possibility of an inorganic *being* with consciousness could be real – maybe through quantum computation – and it is an intriguing possibility to be explored in science-fiction narratives and a challenge for techno-scientific research, but it is not real for the inert machines that surround us.

Abstract consciousness

To grasp the subtleties of Being we need to develop a sense of abstract thinking that allows us to intuit the meanings behind the words, which are abstract principles and not sharply defined ideas. To take into account the complexity of reality it is necessary to enlarge the scope of our thoughts and concepts, instead of trying to reduce everything to the ready-to-use concepts borrowed from particular theories.

Though **the logos** is common, the many live as if they had a wisdom of their own.
(Heraclitus, s/f. DK B2)

Heraclitus' (s/f) idea that “the logos is common” means that we can understand each other because we share a common understanding of reality. Words and technologies help to develop our thoughts and give them shape and form, but the original source of understanding rests behind language and is the same for everybody¹².

Another relevant concept in Heraclitus is that of the Fire,

Fire constitutes and symbolizes both the processes of nature in general and also the light of intelligence. As the source of life and thought, a 'fiery' soul equips people to look into themselves, to discover the formula of nature and to live accordingly.

(Marvin, 1995-2001. paragraph 3)

The Stoics looked back to Heraclitus as the inspiration for their own conception of divine fire, identifying this with the logos that he specifies as the world's explanatory principle.

(Marvin, 1995-2001. paragraph 4)

For these ancient philosophers¹³, there is a connection between life or existence and perception or consciousness. Again it is the act of perception that creates the world by creating the subject and the object, breaking a distinction between the entity who perceives and the world perceived. From this perspective, the childish question of the tree that falls in the forest without anybody noticing or the thought experiment of Schrödinger's cat have an easy answer: cats and trees are perceiving entities able to create reality through their conscious perception. In other words, they have a life of their own and do not need humans to be “observers” to live or die.

12 The other possible interpretation is that understanding and meaning are emerge from the structure of language (structuralism). However, that alone does not seem to be enough to explain the possibilities of human understanding and communication. It will only explain the possibility of communication between humans with a similar cultural and linguistic background. In this second interpretation “logos” could be translated as “language” and not as understanding.

13 Is not incredible that so many philosophers claim to understand what an ancient and obscure philosopher wrote thousands of year ago and that those people seem also to understand each other?

However, Schrodinger's cat is not about a cat, but an example to explain the quantum indeterminacy of atoms: they seem to behave like waves when they are not measured, but get fixed as particles when they are measured or observed¹⁴. The example tries to represent the simultaneous existence of the atom as wave and particle. Of course, we are not going to dig deeper into quantum physics, we just introduce it to put on the table the possibility of thinking in a form of “atomic sentience” that could be related with the atomic agency that New Materialisms claim to identify in inert matter. If atoms react to being observed or measured, maybe their reactions are not just mechanic and they have some sort of basic agency. However, when we link agency to perception or sentience, we realize the need to establish different grades or levels in the way we think about both concepts.

14 Some physicists thought that it is the conscious observation what affected the behavior of the atoms. However, A recent research (Carpenter and Anderson, 2006) claims to demonstrate that it is just the measurement alone what affected “the collapse of a wave-function” and not the conscious observation.

AGENCY:

Agency is the ability of producing actions, which means creating effects that were not previously there – either latent or present. It is a property of the subject that acts¹⁵ or the being from which actions come . Agency is different from the mechanic reaction where no new elements are aggregated to the chain of concatenated events.

The being or subject that acts produces some effect of its own, as an effect of its sentience (or consciousness) that allows it to express itself. Here “conscious” means dynamic processing of “inputs” to produce “outputs” that are indeterminate, not because of the technical impossibility of predicting them, but because “something” (the subject or its consciousness or the property of being or...) is expressing itself in the action. The same agency that produces the act of perception, produces the act of self-expression.

In basic autopoietic systems, this agency is expressed in the *desire* to continue living, both as an entity (adaptation and survival) and as part of a filogenetic phenomena (reproduction). In humans, more complex expressions of the self emerge due to their language mediated consciousness – whether they are based in false or true self-perception. The symbolic dimension of human agency carries with it the need for guidance in informing actions: the eternal problem of human morality and/or ethics arises when they are confronted with the question: How should I act? What do I really want? The language mediated consciousness of humans implies also the burden of responsibility: the ability to respond for our actions, which means to be able to justify, explain or give a reason for the actions we perform¹⁶ .

However, there are and have been mechanistic descriptions of the human being which present it as a machine whose actions are defined by the environment and the conditioning processes that conform the individuals. From this account, humans just react to the circumstances in accordance with previously

15 Linguistically, verbs (actions) are attributed to subjects of the sentence. Only meteorological conditions are impersonal: “it rains” does not present an identifiable subject.

16 For Kant, humans cannot be amoral, because they have reason they are responsible for their actions. Here, we are modifying the taken-for-granted concept of “reason” for “language mediated consciousness”. The use of language carries the ability to explain and make sense of our actions and our existence.

internalized psychological mechanisms and genetic predeterminations. Although it is true that humans' values, interests and inclinations are socially constructed and biologically conditioned, is it possible to think there is no space for self-determination? Do we have choice?

It seems *existentially* necessary to accept the possibility of human agency, that we have some choice in the actions we perform – whether collectively or individually. To understand the nature of that possibility becomes a major concern for philosophers, psychologists, anthropologists... and any reflexive human being.

The decisive moment:

There are some moments when we can feel the tension between different paths of action, in example when something that we want to do scares us. In those situations the “controlled thought” (linguistic or symbolic consciousness) and the instinctive sentence are in conflict, and we can feel the second in which we take the decision that triggers the neuronal synapses that produce the final action.

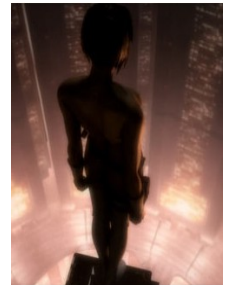

In the long term, the increase of our self-knowledge or maybe the exercise of meditation techniques or psychotherapy could help the person to gain more control over the conditions that influence their acts, impulses, habits, etc. At least that is the take of all the philosophers and thinkers who considered it worth a try to think about ethics and resort to human intelligence to guide human acts. One of them is Spinoza, who dedicated the last chapter of *Ethics, Demonstrated in Geometrical Order* to “The power of the Intellect, or Human freedom”:

At last I come to the final Part of the Ethics, which concerns the method—the way to be followed—to achieve freedom. In this Part, then, I shall deal with reason’s power, showing what reason can do against the affects, and what is the freedom of mind, or what is the same, happiness. This will show us how much more the wise man can do than the ignorant.

(Spinoza, 1677)

Spinoza's philosophy was revolutionary at the time because he presented God as an impersonal Being,

recognized the power of affects in conditioning human will, and confronted many of the humanist assumptions of his time. However, Spinoza clearly recognizes humans as intelligent beings – different from animals, lightings and tables - with the possibility of indirectly controlling their affects by a progressive improvement of their understanding of themselves and their nature.

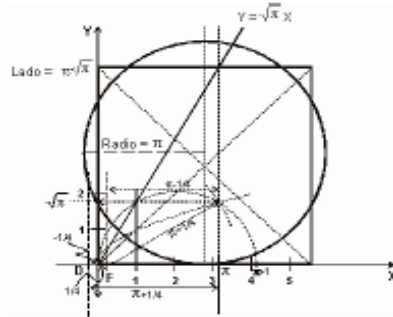

Co-opting Spinoza:

And this power [to make a difference that calls for response], I contend with Spinoza and others, is a power possessed by nonhuman bodies too.

Jane Bennet – *Vibrant Matter* (2010, p. 32)

The concept of non-humans did not exist for Spinoza. He explains the Being as a unified reality from which particular beings emerge as modes of expression. In this context, humans are considered part of nature and affected by external influences that limit their freedom of action. However, as it has been made clear, Spinoza attributed a special kind of agency to humans.

Co-opting Spinoza's thought to support the Latourian concept of non-human agents as qualitatively similar to humans sets an unfortunate source of confusion that harms the possibility of understanding his philosophy.

A single example does not say much, but the practice of co-opting philosophers from the past by distorting their main arguments so they can fit into another argument is a legitimate source of concern, as it seeds confusions and hinders common understanding.

Organic agencies

The agencies of other living beings and their relation to human agencies is another major issue in the New Materialist account of agency. Organic agriculture can be a good example to these hybrid agencies, especially if we also compare it with industrial farming.

Organic agriculture relies in the natural processes of the soil to produce the nutrients needed for the crop to grow. Farmers have to understand those processes and establish a symbiotic relationship with the living beings that enrich the soil. This means that the farmer can facilitate and shape those natural processes to his own advantage, but at the same time he has to adapt his technique to the needs of other living beings. The farmer enters also in the organic process of production, although he is more a coordinator than a passive “actant” – after all he has more intelligence and more agency.

In industrial agriculture, the farmer just organizes the production and applies as many products and technologies as he needs to produce his desired effects. Instead of engaging in a shared agency, he imposes his own on the other beings – plants, microorganisms, etc – by the use of technology – fertilizers, pesticides, OMG's, etc. This creates a parallel system of aggregated agencies that are purely human, because machines and technologies are extensions of human agencies. When *unintended consequences of human actions* come – problems arise, soil impoverishes, water is contaminated, new diseases appear – our surprise would not be attributable to technologies or other non-humans actions, but to the short vision that recommended the use of technologies for which the effects are not well known. However, agency refers to the act itself (who performs the action) and not with the effects of the action that, by definition, are never completely predictable.

Reason against the machine

Any technological device is the result of a social action, a certain set of relations, interests and motivations that produces it, even if the final result does not correspond to the original intentions of the creators. Mechanisms and devices do not have agency, because they do not have interests and are not embedded in a social structure of relations, they are not ends-in-themselves. If we attribute agency to technological systems we are masking the real human agencies that are behind the system, the real set of relations and interests that enable it. Non-human agency is the way of the reification of social relations of power as taken for granted, unchangeable conditions. The human actor amplifies his power through the production and use of technological devices and systems, and if we free him from his responsibility and his agency behind the device, we are immunizing him against social judgment.

POLITICS

Worms and gentrification

We consider it a political act, for example, when people distribute themselves into racially and economically segregated neighborhoods, even if, in doing so, they are following a cultural trend and do not explicitly intend, endorse or even consider the impact of their movements on, say, municipal finances, crime rates or transportation policy. There are many affinities between the acts of persons dragging their belongings to their new homes in the suburbs and the acts of worms.

Jane Bennet – *Vibrant Matter* (2010, p. 98)



In this fragment, Bennet compares the phenomenon of gentrification with the movements of worms. This is a classic example of the *naturalization of a social process*, intended to morally justify social inequalities and political situations presenting them as “natural phenomena”.

Worms move through the territory (probably) driven by the availability of food or whatever other signals they use to make their adaptive “decisions”. People also move to the areas where they can afford to live and feel they are going to be accepted by their neighbors, but the conditions that affect their situation are social, not natural.

Anyway, demographic movements are not considered political acts of the population, but the results of economic and legal conditions, as well as cultural or social dynamics. The regulation of rental prices, the conditions of the loans, the building projections and other economic factors are the main causes for this reconfiguration of cities. Sociocultural elements are also relevant, but they normally play under the rules of law and economics.

The image offered by Bennet, gentrification is like worms extending lush of the jungle into the savanna...

The emphasis in the distributed agency, the assemblages and the non-human actants has the political effect of dissolving the social responsibilities and hiding the social interests behind political decision making. Social and political actions are better explained by the aggregation of agencies than by their distribution. People acting together produce effects that are *more than the sum of the parts*. When the collaboration is extended in time, it produces social subjects or social agents to which individuals submit (voluntarily or not, consciously or not) part of their agencies in order to coordinate their actions towards a shared purpose.

Examples:

Three friends creating a company: it becomes a social agent, a collective subject with a capital, a project, an objective, a culture, etc. The company sells, buys and owns things. The company also counts with processes of decision making that emerge from the interrelations between the partners.

A couple: When two people compromise in a relationship they create a bound that merges their lives in a shared project (at least for some time). And eventually they can form a family.

A crowd engaging in spontaneous collective action: Participating in the shared feeling of the crowd, the participants create a temporary collective subject, and by “flowing with the multitude” they submit part of their agency to the group.

The governance of these collective formations – be it small informal groups, companies, institutions, crowds, or any other – depends on the internal structure of relations, the shared values and the distribution of authority. Some key actors can have a higher responsibility in the collective formation, because they are in key positions.

When things “go wrong” in any of these organizations and there is a claim for accountability, it is possible to analyze the distribution of responsibilities according to predefined criteria or principles. When action happens, agency is aggregated to produce effects and the participants act as a whole. Then, if we want to understand how things happen, we can study how actions aggregated and distribute responsibility among the social or individual agents that collaborated to produce the final outcome. This process consists of analyzing what particular self-expressive elements the subjects introduced in

the equation and what their role was in the process. Responsibility means that they have to respond, justify, and explain what they really did, not necessarily the effects of the collective action.

Identification of responsibilities is not looking for someone to blame, but for the understanding of the social structures and dynamic that create the negative or positive effects. Responsibility can also be normative and projected to the future: when an organization wants to introduce changes or accomplish anything, people and groups are designated responsible for that objective, and are given the necessary authority to reach it.

In the Latourian model proposed by Bennet, agency is distributed and responsibility is aggregated. So every actor acts on their own creating effects for which nobody would be made responsible. That model not only eliminates the possibility of identifying responsibilities, but also the possibility of designing those responsible to enact the change or prevent the repetition of problems; in other words, it hinders regulation and coordination of social action.

It should also be noted that the principles of responsibility are always socially and culturally defined. The definition of social and collective objectives, values and principles is a political and cultural process. The attribution of the responsibilities is dependent on the moral or ethical principles socially defined. Understanding how things happen can also help us to reflect on those moral or ethical principles, but those are partially independent of that process. In other words, the moral/ethical appreciation of an act is independent of the understanding of agencies and responsibilities. It is a process that has nothing to do with morality or political condemnation, but with the basic fact of attributing actions to (human and social) actors.

What happened in the Blackout described in Bennet's *Vibrant Matter*?

According to Bennet's account of the events:

1. A brush fire and other minor errors created a failure in some electric centrals.
2. These failures created an escalation of errors in hundreds of electric centrals causing the Blackout in a great part of the country. This was caused by:

1. The feedback systems that automatically stop the centrals when they detect overheating or other dangerous conditions.
2. The deficient organization of the grid and the electric flows due to the liberalization of the market. This resulted in inefficient routes for the distribution of energy and a shortage of reactive energy.

First, we have several failures caused by natural conditions and, maybe, by the lack of personnel in the electric plants. Secondly, we have a chain reaction that maximizes the negative effects of those failures. The problem is raised mainly because of this secondary failure, and the nominated responsible are: the engineers that designated the feedback prevention systems and the governmental agencies that regulate the electrical market.

Grids, electrons and meteorological conditions can be relieved from (social) responsibility, after all, nobody elected them, they are not able to answer our questions, and they are not able to improve the conditions to prevent the problem in the future. Consumers can also be relieved, because they had no authority in building or organizing the centrals. The engineer's work could be investigated in search of any technical negligence or need of improvement. However, chances are their conservative feedback prevention systems saved the centrals from more serious damage. On the other hand, the governmental agencies responsible for the regulation of the electrical market had developed rules that created an inefficient distribution of energy. Governmental agencies have the political authority to legislate over the electric market and to impose on economic actors the proper measures of safety and efficiency. Also, they are representatives of the legitimate political authority in the territory. Another possibility is that companies are pressing the governmental agencies so they cannot do anything, in which case the answer would be to change the political system, to empower governmental agencies to legislate properly in order to prevent future failures.

However, responsibility depends always in the social definition of the situation. The analysis just made rests on the assumption that maintaining the electrical system operative is the desired aim. In case the actors implied considered market freedom to be more important, then systemic failures should be accepted as an inevitable externality of that social ethos. Even in the case when blackouts can be

socially justifiable in the benefit of market freedom, distributed agency distracts us to see how the social actors are situated and how their relations work.

“In Search of a Better World”

In a world of distributed agency, a hesitant attitude toward assigning singular blame becomes a presumptive virtue. [...] Outrage will and should not disappear, but a politics devoted too exclusively to moral condemnation and not enough to a cultivated discernment of the web of agentic capacities can do little good. A moralized politics of good and evil, or singular agents who must be made to pay for their sins (be them bin Laden, Saddam Husein, or Bush) becomes unethical to the degree that it legitimates vengeance and elevates violence to the tool of first resort.

Jane Bennet – *Vibrant Matter* (2010, p. 38)

We can agree with Bennet in this fragment. Blaming, moral condemnation, moralized politics, vengeance and violence are not a good path for society to follow. However, the “cultivated discernment of the web of agentic capacities” should take into account the specific characteristics of all the different human agents, when they act as individuals or social entities, as well as the ways in which their agencies aggregate to produce social phenomena. It would also reflect on the particularities of human action as entities with a “language mediated consciousness” (or the ability to think), which allows them to develop ethics. Furthermore, it would identify the role of other organic agencies and ecosystems in social processes and how proper forms of hybridization can produce better symbiotic relations. And finally, it will take into account the affordances of technological and bureaucratic systems that act as an extension of human agencies and social interests and not as “actants” with their own agency. Otherwise, we will equate the value of humans, animals and objects as utilities and commodities ready to be used, and instead of promoting respect for other beings and natural processes, we will be pulling out the respect for the living and the humans.

Bibliography:

Bennet, Jane (2010). *Vibrant Matter*. Durham and London: Duke University Press.

DeLanda, Manuel (2004). *Intensive Science and Virtual Philosophy*. London: Continuum

Gibson, William (1984). *Neuromancer*. New York: Ace

Hayles, N. Katherine (1999). *How We Became Posthuman*. Chicago University Press.

Heraclitus (s/f) Fragments. Retrieved June 1, 2013 in

<http://www.heraclitusfragments.com/B30/index.html>

Internet Encyclopedia of Philosophy, (s/f) Human Rights. Retrieved June 1, 2013 in

<http://www.iep.utm.edu/hum-rts/>

Marvin, Chris (1995-2000). Heraclitus of Ephesus. *The Window. Philosophy of the Internet*. Retrieved June 1, 2013 in <http://www.trincoll.edu/depts/phil/philo/phils/heraclitus.html>

Maturana, Humberto and Varela, Francisco "Chapter 1: On Machines, Living and Other," *Autopoiesis: The Organization of the Living* (D.Reidl, 1980, originally published 1972).

Morin, Edgar. (1990) *Introduction à la pensée complexe*, Paris: Ed. Points.

Morin, Edgar (2007a). *On complexity*. Cresskill, NJ: Hampton Press.

Morin, Edgar (2007b). Restricted complexity, general complexity. In C. Gershenson, D. Aerts, & B. Edmonds (Eds.), *Worldviews, science, and us: Philosophy and complexity*. New York: World Scientific Publishing Company.

Spinoza, Benedict (2004. First published in 1677). *Ethics Demonstrated in Geometrical Order*. Edited by Jonathan Bennet. Retrieved June 1, 2013 in <http://www.earlymoderntexts.com/pdf/spinethi.pdf>

Stanford Encyclopedia of Philosophy, 2004. Consciousness. Retrieved June 1 2013 in <http://plato.stanford.edu/entries/consciousness/>